

Leak-Free Load-Control Valve, Size 6

$Q_{\max} = 50 \text{ l/min (13 gpm)}$, $p_{\max} = 420 \text{ bar (6000 psi)}$
leak-proof, pilot operated, flange- or pipe design
Series BBV 6...

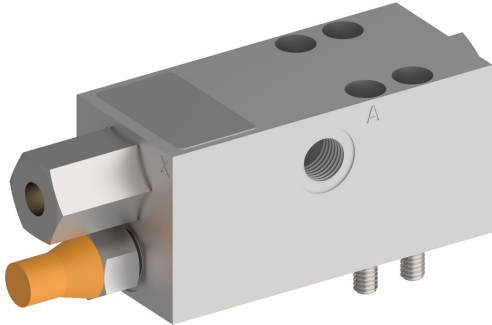

- Two-stage load-control valve and bypass check valve are functionally combined in one coaxial valve assembly
- Leak-free load holding
- The load pressure has very little influence on the pilot pressure required → area ratio 1:66
- Guaranteed closing force for the load-control assembly → reliable shut-off even with a broken spring
- Thanks to the various pilot control styles, the valve can always be adapted to the system requirements
- Hardened, ground and lapped seat valve components ensure permanent leaktightness and long service life
- Optionally with pilot operated secondary pressure relief valve

1 Description

Load-control valves in this series prevent hydraulic actuators from running ahead of the available oil supply. In one valve, they combine the functions of load-holding, safety and pipe-rupture protection. These hydraulic load-control valves from the series BBV 6... are pilot operated as well as high performance valves of size 6 and available as flange and piping valves. They are ideally suited for use in high-

pressure applications up to 420 bar (6000 psi). Thanks to the various pilot control variants, the cartridge can be optimally adapted to the system requirements. The compact design allows for minimum installation space. These valves are mainly used in mobile and stationary applications (e.g. for speed control of cylinders, hydraulic motors or on the luffing mechanisms).

2 Symbol

without secondary pressure relief valve

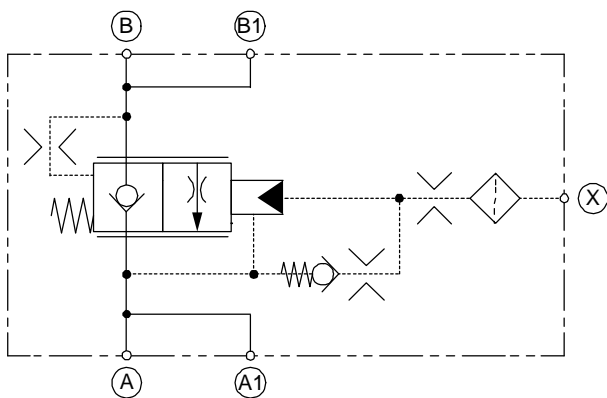

with secondary pressure relief valve

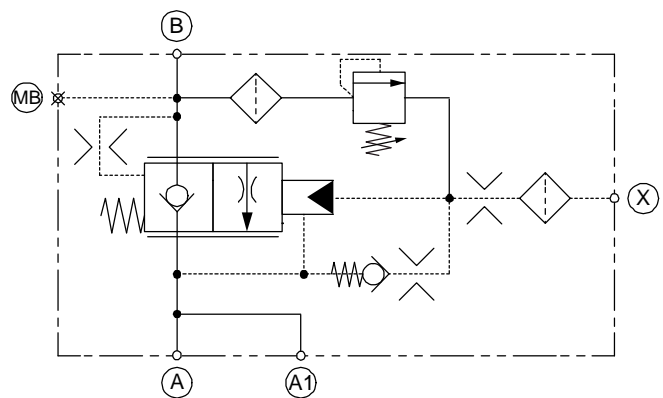

3 Technical data

General characteristics		Description, value, unit
Designation		leak-free load-control valve
Design		leak-proof, hydraulically pilot operated, flange or pipe design
Size		size 6
Mounting method		flanged (SAE 6000 psi) or piped
Main ports	A, A1	G 3/8", ISO 1179-1 SAE 1/2" 6000 psi (mit SV) ISO 6162-2 DN13 M8 (SAE J518 Code 62-8, M8x1.25)
Main port	B	
Main port	B, B1	G 3/8", ISO 1179-1 (ohne SV)
Control port	X	G 3/8", ISO 1179-1 (ohne SV)
Measuring port	MB	G 1/4", ISO 1179-1
Weight		without SV: 2.0 kg (4.40 lbs) with SV: 2.9 kg (6.39 lbs)
Mounting attitude		unrestricted
Ambient temperature range		-25 °C ... +80 °C (-13 °F ... +176 °F) (others on application)
Surface corrosion protection		nothing

Hydraulic characteristics		Description, value, unit
Maximum operating pressure		420 bar (6000 psi)
Maximum flow rate		50 l/min (13 gpm)
Flow direction		A → B, free flow through check valve B → A, controlled flow
Operator type		hydraulic proportional
Opening pilot ratio		1:66
Hydraulic fluid		HL and HLP mineral oil to DIN 51 524; for other fluids, please contact BUCHER
Hydraulic fluid temperature range		- 25 °C ... + 80 °C (-13 °F ... +176 °F)
Temperature rating of seals	NBR	- 25 °C ... + 100 °C (-13 °F ... +212 °F)
	FKM	- 20 °C ... + 200 °C (-4 °F ... +392 °F)
	MIL	- 55 °C ... + 80 °C (-67 °F ... +176 °F)
Viscosity range		2.8...1500 mm ² /s (cSt), recommended 10...380 mm ² /s (cSt)
Minimum fluid cleanliness Cleanliness class to ISO 4406 : 1999		class 20/17/14

4 Construction and function

4.1 Neutral position (load pressure at B, ports A and X depressurized)

In the neutral position, there is zero leakage from B → A. The valve is held closed by the check valve spring, which acts the pilot valve ball and thus on the control spool, and also by the load pressure, which acts on the rear side of the pilot valve ball and the control spool.

4.2 Check valve function (flow from A → B)

To raise the actuator, pump pressure is applied via port A to the valve seat area of the control spool and causes the control spool together with the pilot ball to open, pushing against the check valve spring. Due to the small effective area of the pilot ball, when the control spool moves in the opening direction during the check valve function the pilot ball moves with it, and does not lift from its seat in the spool.

4.3 Lowering function (flow from B → A)

Initial decompression

The pilot pressure at port X moves the pilot piston in opposition to the pilot spring, lifting the pilot ball from its seat in the control spool. The load pressure behind the control spool now decays as it escapes past the pilot ball seat to port A.

Opening the control spool

With further increase in the pilot pressure, the pilot piston compresses the pilot spring still more. It then makes direct contact with the control spool and pushes it open against the check valve spring.

The pilot pressure acting on the pilot piston therefore controls the open metering area of the control spool, and consequently the flow rate from B → A.

Damping

The system can be protected against oscillations by using suitable damping orifices. The effect of the bypass orifice from X → A is to make it necessary to use higher pilot pressures (pressure divider function) and this improves the damping behaviour.

The orifices are protected against contamination by a mesh filter at port X and a check valve that prevents flow from A.

4.4 Secondary pressure relief valve (SV)

The secondary pressure relief valve is connected directly to the cylinder port B. When the pressure setting (which is externally adjustable) is reached, the relief valve poppet opens to create a flow path to the pilot chamber X. This causes the pressure in the pilot chamber to rise, which moves the pilot piston in the opening direction. The excess pressure in B is now relieved to A through the open control spool.



IMPORTANT!:

For more information on the secondary pressure relief valve (SV) see documentation 300-P-9050065 on our website.

5 Performance graphs

measured with oil viscosity 33 mm²/s (cSt)

$\Delta p = f(Q)$ Pressure drop - Flow rate characteristic
Check valve function, A → B

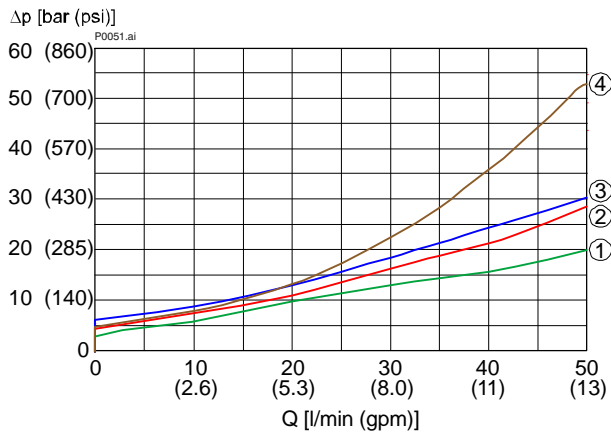

$\Delta p = f(Q)$ Pressure drop - Flow rate characteristic
Lowering function, B → A, fully open

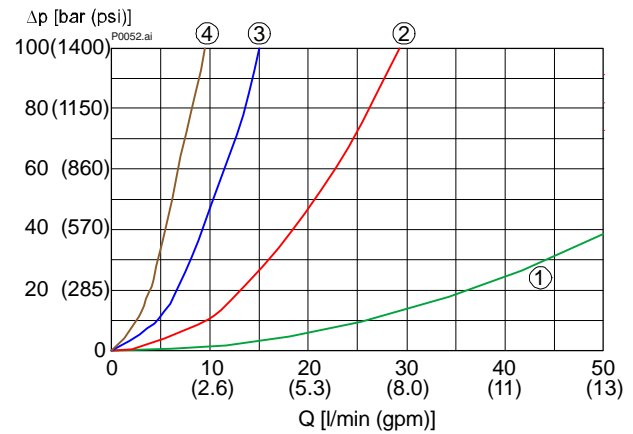

$p = f(Q)$ Pressure - Flow rate characteristic
Pilot pressure pX @ 200 bar load pressure, B → A

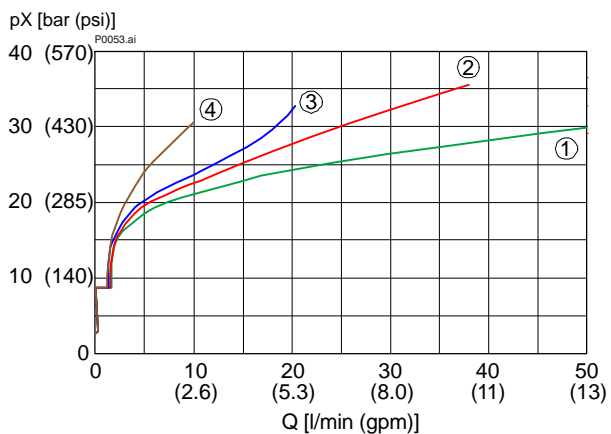

$p = f(Q)$ Pressure - Flow rate characteristic
Secondary pressure relief valve (SV)

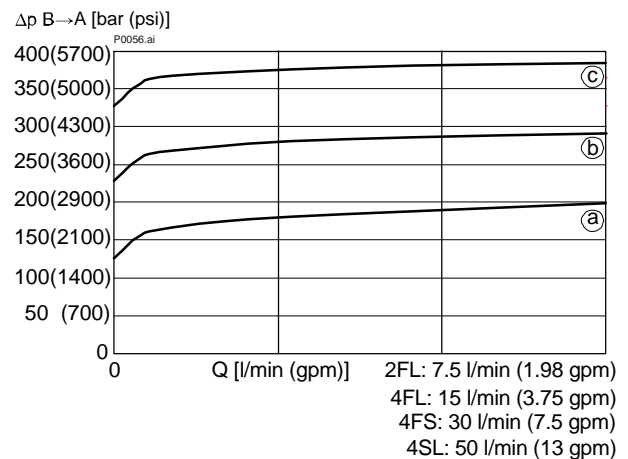

Legend:
(applies to all characteristic curves)

1	piston type 4SL
2	piston type 4FS
3	piston type 4FL
4	piston type 2FL
a	Setting 130 bar (1900 psi)
b	Setting 230 bar (3300 psi)
c	Setting 330 bar (4700 psi)

5.1 Orifice names

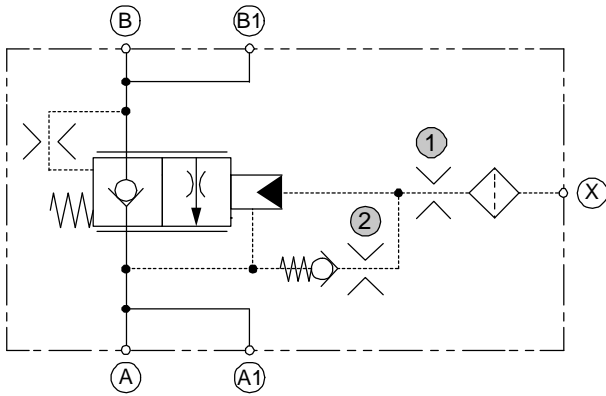

1	damping orifice
2	bypass orifice

5.2 Table of opening pressures

Opening pressure at 200 bar load pressure (theoretical values).

pX pre-opening [bar / (psi)]	pX start of opening [bar / (psi)]	pX fully open [bar / (psi)]	Bypass orifice [mm]	damping orifice [mm]
9.0 / (130.5)	16.0 / (232.0)	33.0 / (478.6)	Ø 0.00	Ø 0.25...0.40
12.0 / (174.0)	21.0 / (304.5)	45.0 / (652.6)	Ø 0.30	Ø 0.40
14.0 / (203.0)	25.0 / (362.5)	52.5 / (761.4)	Ø 0.30	Ø 0.35
14.0 / (203.0)	25.0 / (362.5)	54.0 / (783.2)	Ø 0.35	Ø 0.40
18.0 / (261.0)	32.0 / (464.1)	67.5 / (979.0)	Ø 0.30	Ø 0.30
18.0 / (261.0)	32.0 / (464.1)	67.5 / (979.0)	Ø 0.35	Ø 0.35
18.0 / (261.0)	32.0 / (464.1)	67.5 / (979.0)	Ø 0.40	Ø 0.40
23.0 / (333.5)	42.0 / (609.1)	88.5 / (1283.5)	Ø 0.45	Ø 0.40
24.0 / (348.0)	43.0 / (623.6)	91.5 / (1327.0)	Ø 0.40	Ø 0.35
26.0 / (377.0)	46.0 / (667.1)	97.5 / (1414.1)	Ø 0.35	Ø 0.30
34.0 / (493.1)	60.0 / (870.2)	126.0 / (1827.4)	Ø 0.45	Ø 0.35
37.0 / (536.6)	67.0 / (971.7)	141.0 / (2045.0)	Ø 0.40	Ø 0.30
54.0 / (783.2)	97.0 / (1406.8)	205.5 / (2980.5)	Ø 0.45	Ø 0.30



IMPORTANT!: The opening pressure can be adjusted to the system by changing the orifices.

6 Dimensions & sectional view

Example for the dimensional units:
 0.79 = 0.79 mm [millimeter]
 (.031) = 0.031" [inch]

Without secondary pressure relief valve (SV)

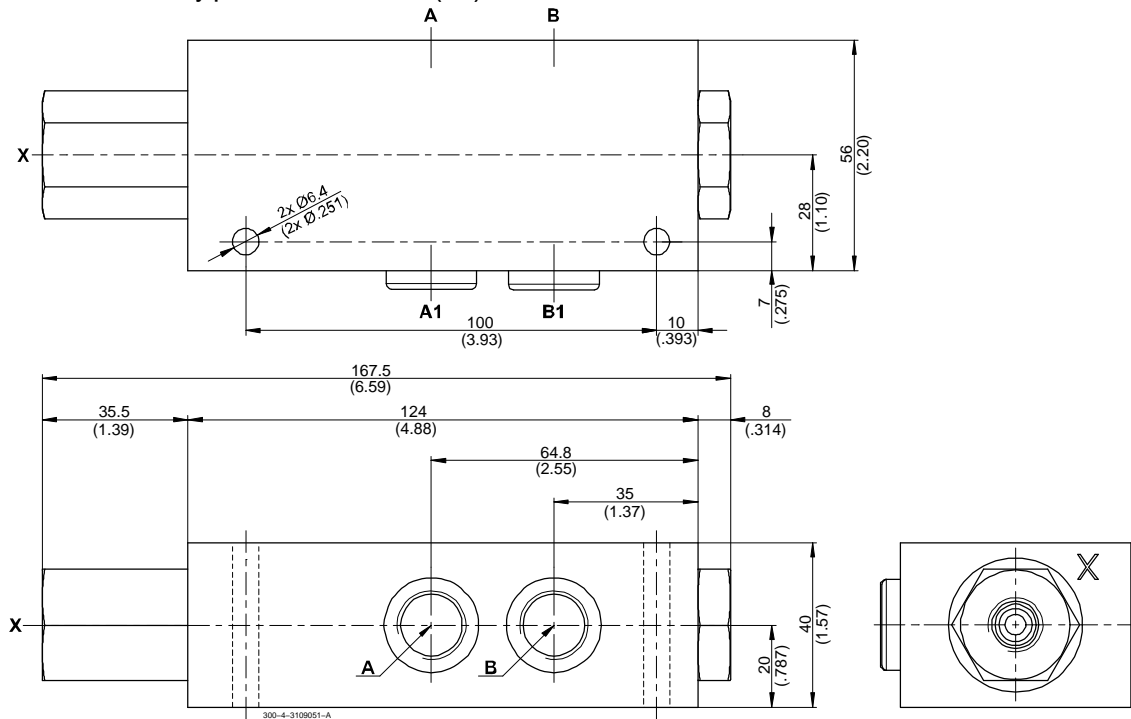

With secondary pressure relief valve (SV)

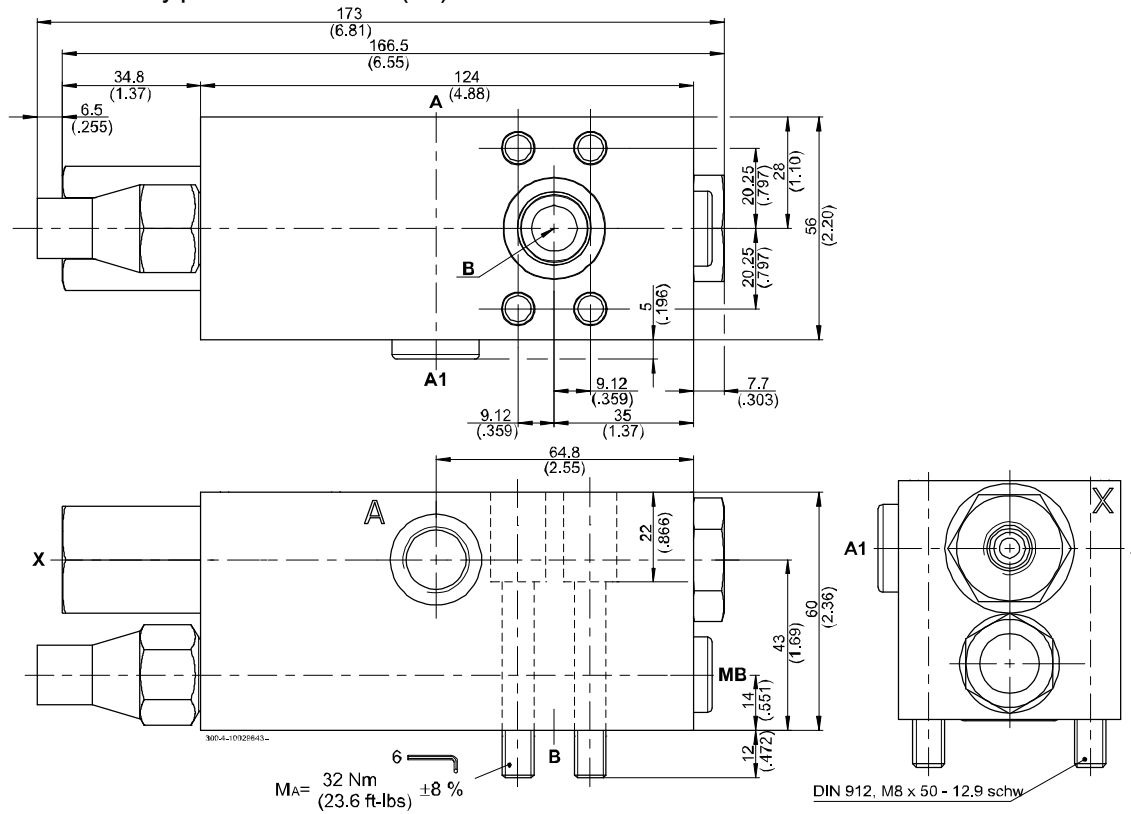

7 Installation information

**IMPORTANT!:**

Designing load-control valves requires specialist technical knowledge and product knowledge. Safety applications must be verified by adequate tests to ensure safety in actual use.

**ATTENTION!**

Only qualified personnel with mechanical skills may carry out any maintenance work. Generally, the only work that should ever be undertaken is to check, and possibly replace, the seals. When changing seals, oil or grease the new seals thoroughly before fitting them.

**IMPORTANT!:**

The valve may only be used for its intended purpose within its nominal rating. If you plan to use it outside the nominal rating, you must contact the valve manufacturer.

The ultimate responsibility for safety in the installation and use rests with the end-machine manufacturer of the mobile application.

**IMPORTANT!:**

The port threads conform to DIN 3852 T1. Use screws to DIN 912, grad 12.9, to mount the valve.

Tightening torques as per the manufacturer's instructions.

**IMPORTANT!:**

Protect seals and flange faces from damage. The mating flange face must be of the quality specified in the data sheet!

Pay attention to the port designations.

**IMPORTANT!:**

Seal kit with the external seals is available on application.

8 Application examples

8.1 Speed control of a cylinder

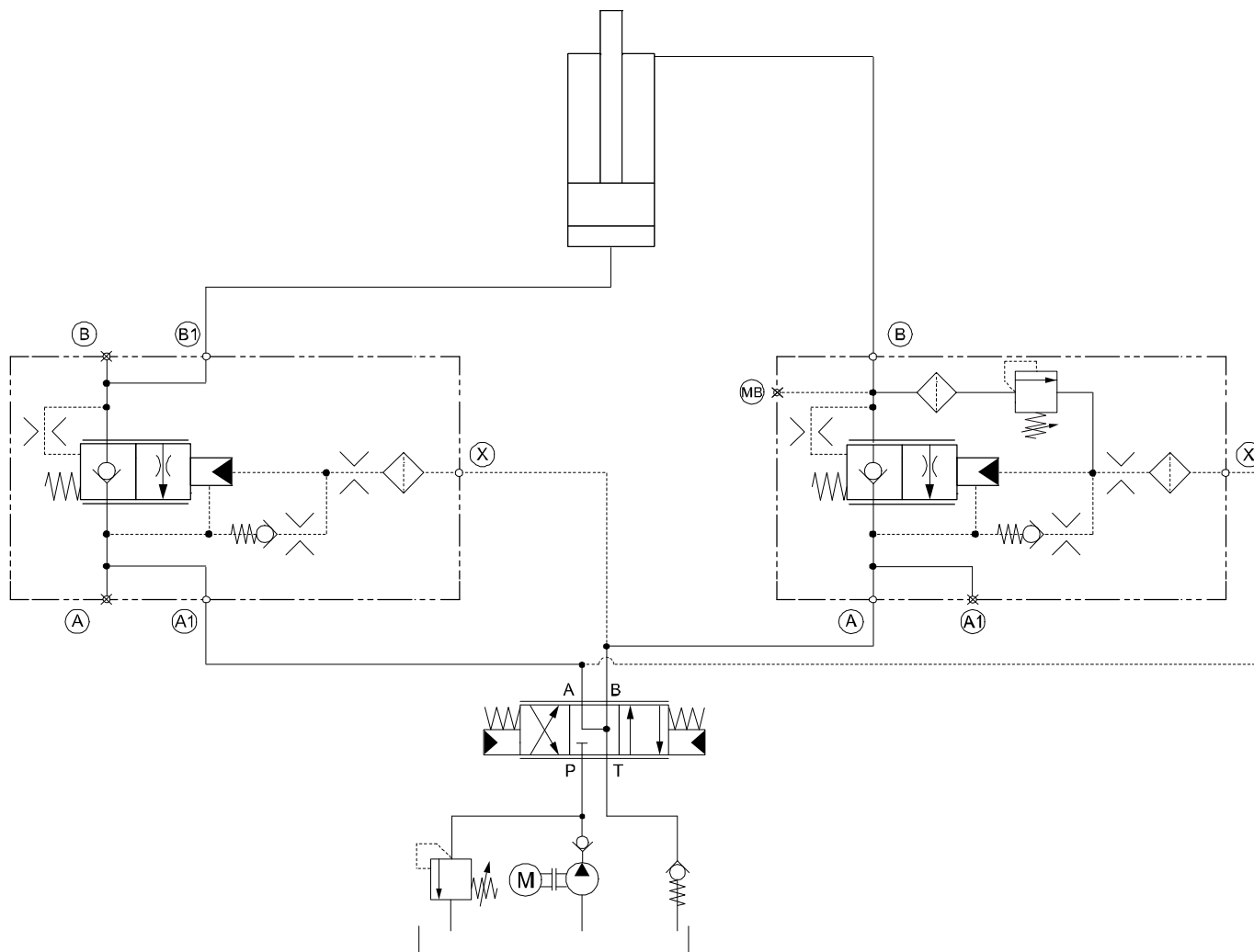

Further possible applications are:

- Safety function for booms, derricking gear, etc.
- Speed control of hydraulic motors and derricking gear

9 Ordering code

e.g. **BBV** **6** - **2FL** / **0.30** / **BY** - **0.00** / **SV** / **500** / **N**

- BBV = leak-free load control valve
- 6 = size 6
- 2FL = piston type 2FL
- 4FL = piston type 4FL
- 4FS = piston type 4FS
- 4SL = piston type 4SL
- 0.30 = damping orifice Ø0.30
- 0.35 = damping orifice Ø0.35
- 0.40 = damping orifice Ø0.40
- BY = with bypass (standard)
- 0.00 = bypass orifice Ø0.00 (closed)
- 0.30 = bypass orifice Ø0.30
- 0.35 = bypass orifice Ø0.35
- 0.40 = bypass orifice Ø0.40
- 0.45 = bypass orifice Ø0.45
- (blank) = without secondary pressure relief valve (SV)
- SV = with secondary pressure relief valve (SV)
- ... = setting of the secondary pressure relief valve (SV)
50...500 bar (700...7200 psi)
- N = NBR (Nitrile) seals (standard)
- V = FKM (Viton) seals
- T = MIL (low temperature) seals
(special seals - please contact BUCHER)



IMPORTANT!:

Additional documentation and 3D models (.stp or .igs format) can be downloaded from www.bucherhydraulics.com (LOGintern area; registration is necessary)



IMPORTANT!:

We also offer customised solutions. Please talk to our sales team.

info.ch@bucherhydraulics.com

www.bucherhydraulics.com

© 2019 by Bucher Hydraulics AG, CH-6345 Neuheim

All rights reserved.

Data is provided for the purpose of product description only, and must not be construed as warranted characteristics in the legal sense. The information does not relieve users from the duty of conducting their own evaluations and tests. Because the products are subject to continual improvement, we reserve the right to amend the product specifications contained in this catalogue.

Classification: 430.325.360.305.315.325.305.310